

OIL WIPER RINGS

XBM-1328-L-1

Assembly Instructions Oil Wiper Rings

**AJAX PART NUMBER
XBM-1328-L-1**

Oil Wiper Rings are most frequently installed in a case mounted on the crankcase bulkhead wall of a reciprocating engine to minimize the migration of oil on the piston rod as it moves in and out of the crankcase.

There are a number of basic conditions that must be met to assure effective oil control:

1. The rings should fit the rod to within 0.002".
2. The total side clearance between the

rings and groove walls should not exceed 0.0005" per ring **at operating temperature***. If there is too much clearance, the rings may cock and dig into the rod. However, if there is insufficient side clearance, metal rings may bind in the grooves and score the rod.

3. Adequate drainage of the ring groove is essential.
4. Suitable venting must be provided to permit entry of air to displace the draining oil.

Proper Location for Rings:

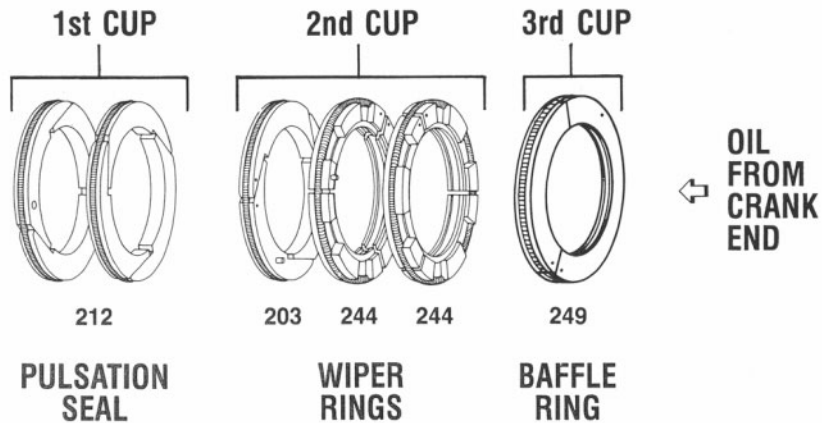

OIL WIPER RINGS

XBM-1330-E-1

Assembly Instructions Oil Wiper Rings AJAX PART NUMBER XBM-1330-E-1

Oil Wiper Rings are most frequently installed in a case mounted on the crankcase bulkhead wall of a reciprocating engine to minimize the migration of oil on the piston rod as it moves in and out of the crankcase.

There are a number of basic conditions that must be met to assure effective oil control:

1. The rings should fit the rod to within 0.002".
2. The total side clearance between the

rings and groove walls should not exceed 0.0005" per ring at **operating temperature***. If there is too much clearance, the rings may cock and dig into the rod. However, if there is insufficient side clearance, metal rings may bind in the grooves and score the rod.

3. Adequate drainage of the ring groove is essential.
4. Suitable venting must be provided to permit entry of air to displace the draining oil.

Proper Location for Rings:

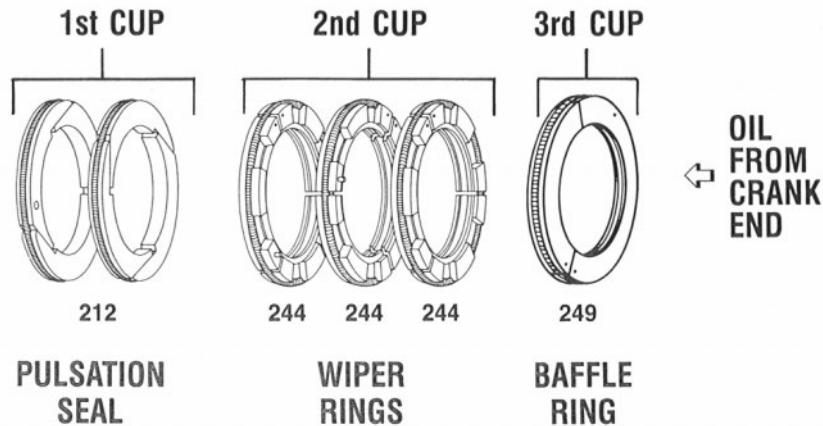

OIL WIPER RINGS

XBM-1333-K-1

Assembly Instructions Oil Wiper Rings AJAX PART NUMBER XBM-1333-K-1

Oil Wiper Rings are most frequently installed in a case mounted on the crankcase bulkhead wall of a reciprocating engine to minimize the migration of oil on the piston rod as it moves in and out of the crankcase.

There are a number of basic conditions that must be met to assure effective oil control:

1. The rings should fit the rod to within 0.002".
2. The total side clearance between the

rings and groove walls should not exceed 0.0005" per ring **at operating temperature***. If there is too much clearance, the rings may cock and dig into the rod. However, if there is insufficient side clearance, metal rings may bind in the grooves and score the rod.

3. Adequate drainage of the ring groove is essential.
4. Suitable venting must be provided to permit entry of air to displace the draining oil.

Proper Location for Rings:

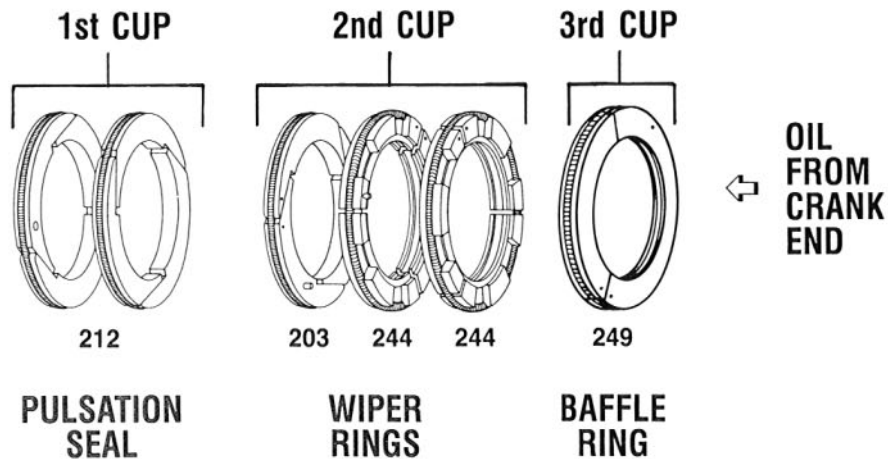

OIL WIPER RINGS

XBM-1334-J-1

Assembly Instructions Oil Wiper Rings AJAX PART NUMBER XBM-1334-J-1

Oil Wiper Rings are most frequently installed in a case mounted on the crankcase bulkhead wall of a reciprocating engine to minimize the migration of oil on the piston rod as it moves in and out of the crankcase.

There are a number of basic conditions that must be met to assure effective oil control:

1. The rings should fit the rod to within 0.002".
2. The total side clearance between the

rings and groove walls should not exceed 0.0005" per ring at **operating temperature***. If there is too much clearance, the rings may cock and dig into the rod. However, if there is insufficient side clearance, metal rings may bind in the grooves and score the rod.

3. Adequate drainage of the ring groove is essential.
4. Suitable venting must be provided to permit entry of air to displace the draining oil.

Proper Location for Rings:

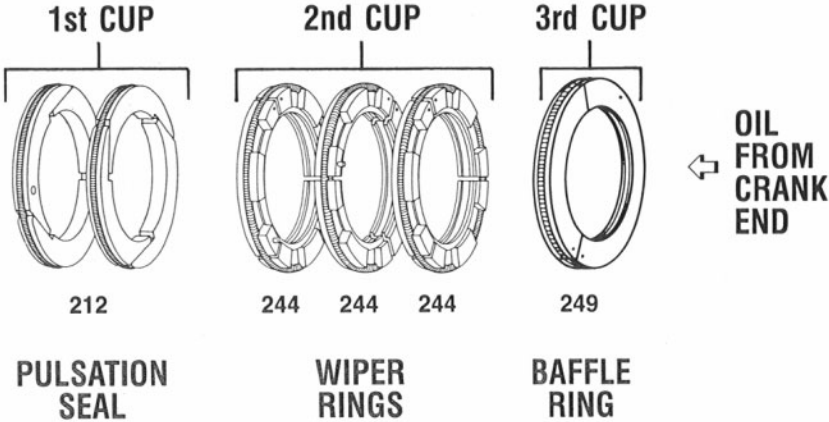

OIL WIPER RINGS

L-1770/2165

Assembly Instructions Oil Wiper Rings

ENGINE NUMBER
1770/2165

Packing Set #860-LC-1770

Oil Wiper Rings are most frequently installed in a case mounted on the crankcase bulkhead wall of a reciprocating engine to minimize the migration of oil on the piston rod as it moves in and out of the crankcase.

There are a number of basic conditions that must be met to assure effective oil control:

1. The rings should fit the rod to within 0.002".
2. The total side clearance between the

rings and groove walls should not exceed 0.0005" per ring **at operating temperature***. If there is too much clearance, the rings may cock and dig into the rod. However, if there is insufficient side clearance, metal rings may bind in the grooves and score the rod.

3. Adequate drainage of the ring groove is essential.
4. Suitable venting must be provided to permit entry of air to displace the draining oil.

Proper Location for Rings:

